

## Vehicle Inspectors Bulletin No. 13

Transport Services Division

Effective Date: 07 February 2011

Issued by Road Transport Compliance

For: ♦ Transport Inspectors ♦ Authorised Inspectors ♦ NT Police Outstations

# Light Trailer Requirements - Compliance with VSB1

## Background

All new trailers (including imported trailers), not exceeding 4500kg Aggregate Trailer Mass (ATM), presented for registration in the Northern Territory must comply with requirements of the National Code of Practice for Building Small Trailers – Vehicle Standards Bulletin (VSB)1 – as published by the Commonwealth Department of Infrastructure, Transport, Regional Development and Local Government.

VSB1 summarises the requirements for compliance with Australian Design Rules (ADRs).

In verifying compliance with VSB1, potential areas of non-compliance have been highlighted.

### Note:

- i. *ATM is the total mass of the trailer when carrying the maximum load recommended by the trailer manufacturer.*
- ii. *Trailers manufactured prior to the commencement of ADRs are required to comply with Australian Vehicle Standards Rules (AVSRs).*

## Purpose

The purpose of this Bulletin is to highlight these potential areas of non-compliance and provide guidance in compliance with VSB1. This Bulletin should be read in conjunction with VSB1 and other applicable references – refer [Weblinks and References](#).

## Action

Transport Inspectors and Authorised Inspectors who are appointed to carry out compliance checks or registration renewal inspections on light trailers must not pass light trailers for registration unless the trailer complies with VSB1, as applicable.

### Darwin

Vehicle Standards Centre  
Goyder Road, Parap  
Phone: (08) 8999 3127  
(08) 8999 3133  
Fax: (08) 8999 3187

### Katherine

Katherine Weigh Bridge  
Stuart Highway  
Phone: (08) 8973 8791  
Fax: (08) 8973 8762

### Alice Springs

Vehicle Standards Centre  
North Stuart Highway  
Phone: (08) 8951 5297  
Fax: (08) 8951 5313

## Potential Areas of Non-Compliance

The potential areas of non-compliance include:

1.	Vehicle or Trailer Identification Plate - (VSB 1 Section 7) .....	2
2.	Lights and Reflectors - (VSB 1 Section 13).....	3
3.	Braking Systems - (VSB 1 Section 15).....	4
4.	Tow Couplings – General - (VSB 1 Section 16).....	4
5.	Tow Coupling Attachment - (VSB 1 Section 16) .....	4
6.	Tow Couplings – 50mm Ball Type Coupling Body Markings (up to 3500kg ATM) - (VSB 1 Section 16).....	5
7.	Safety Chains - (VSB 1 Section 16) .....	5
8.	Axle Rating (including wheels and tyres) and Suspension - (VSB 1 Section 19).....	7
9.	Maximum Trailer Dimensions (Pig Trailers) - (VSB 1 Section 21).....	8
10.	Weblinks and References .....	8

### 1. Vehicle or Trailer Identification Plate - (VSB 1 Section 7)

- 1.1. All new trailers must have a vehicle plate securely affixed.
- 1.2. The trailer manufacturer (person who built or assembled the trailer) must affix a vehicle plate to the trailer in a prominent position.
- 1.3. The vehicle plate must be of durable, non-corrosive metal and must be affixed to the trailer in a position where it may be readily examined and where it will be protected from damage by weather and debris (i.e. stones, etc).
- 1.4. The vehicle plate must be permanently affixed – e.g. pop rivets, hammer drive screws or welding. Affixing plates with adhesives is not acceptable.
- 1.5. The vehicle plate must show at least the following information:
  - a) Trailer Model;
  - b) Vehicle Identification Number - issued by the Registration Authority;  
(It is advisable that it also be stamped directly onto the frame of the trailer)
  - c) Manufacturer's Name;
  - d) Aggregate Trailer Mass (kg);
  - e) Date of Manufacture (month/year, e.g. 02/08); and

f) The Certification Statement (specified below):

f(i) The certification statement for new trailers is:

**This trailer was manufactured to comply with the *Motor Vehicle Standards Act 1989***

**or**

f(ii) The certification statement for used imported trailers is:

**This trailer is an imported used trailer.**

**It has been modified and assessed to comply with the *Motor Vehicle Standards Act 1989***

**Note:**

- iii. *The necessary trailer information will need to be marked (i.e. stamped or engraved) on the vehicle plate by the trailer manufacturer.*
- iv. *These plates may be available for purchase from trailer parts retailers.*
- v. *A vehicle plate is not required for a trailer manufactured prior to June 1989.*

## **2. Lights and Reflectors - (VSB 1 Section 13)**

- 2.1. Trailers exceeding 2.1 metres in width require side marker lamps (clearance lights).
- 2.2. Lamps on a trailer must not show red light to the front or white light to the rear (except reverse lamp).
- 2.3. When fitting reflectors:
  - 2.3.1. white to the front;
  - 2.3.2. amber to the side; and
  - 2.3.3. red to the rear (usually incorporated in the tail light assembly).
- 2.4. If using a light board, red reflectors are still required on the rear of the trailer itself.
- 2.5. Rear lamps and number plate are to be clearly visible from the rear at all times.

### 3. Braking Systems - (VSB 1 Section 15)

- 3.1. Single-axle trailers with a Gross Trailer Mass (GTM) not exceeding 750kg do not require brakes.
- 3.2. Trailers up to 2000kg GTM (except single-axle trailers with GTM not exceeding 750kg) must have brakes operating on at least one axle which can be an 'over-run' braking system.
- 3.3. Trailers over 2000kg GTM must have brakes operating on all wheels which must be a 'break-away' braking system where the trailer brakes are activated if the trailer detaches from the towing vehicle.

**Note:**

- i. *Two-axle trailers with axle centres spaced less than one metre apart is regarded as a single axle – refer to [Axle Rating and Suspension](#).*
- ii. *Gross Trailer Mass (GTM) is the mass transmitted to the ground by the tyres of the trailer when coupled to a towing vehicle and carrying the maximum load recommended by the manufacturer approximately uniformly distributed over the load bearing area.*

### 4. Tow Couplings – General - (VSB 1 Section 16)

- 4.1. Trailers up to 3500kg Aggregate Trailer Mass (ATM) must have a quick release coupling which is designed to be engaged and disengaged without the use of tools.
- 4.2. It must be of a positive locking type with provision for a second independent device. The locking must be readily verifiable by visual inspection.
- 4.3. For trailers with an ATM greater than 3500kg, refer directly to [ADR 62/00](#), [ADR 62/01](#) or [ADR 62/02](#) "*Mechanical Connection Between Vehicles*", as applicable.

### 5. Tow Coupling Attachment - (VSB 1 Section 16)

- 5.1. Tow couplings shall be attached in accordance with the manufacturer's instructions and specifications, viz.:
  - a) Grade, dimension and tightening torque of attaching bolts (where applicable);
  - b) Weld size and weld procedure (where applicable); and
  - c) Recommended attaching position.

**Note:**

- i. *Where the tow coupling prohibits welding as a method of attachment to the drawbar, an alternative method of attachment must be used (i.e. nuts and bolts).*

## 6. Tow Couplings – 50mm Ball Type Coupling Body Markings (up to 3500kg ATM) - (VSB 1 Section 16)

- 6.1. Clause 12.4 of ADR 62 provides for two marking options for 50mm Coupling Bodies:

### Option 1 Australian Standards “AS 4177-2004 Caravan and towing components”

Markings complying with AS 4177-2004 shall be legibly and permanently marked with the following information (characters must be no less than 5mm in height):

- a) The manufacturer's name or trademark;
  - b) The mark '50' to indicate the size of towball for which it is intended;
  - c) Maximum rating in kilograms, e.g. 750kg, or 2000kg, or 3500kg;
  - d) A code to indicate serial number, batch, production date, or similar; and
  - e(i) The words '**DO NOT WELD**' if the coupling is manufactured from non-weldable material;
- or
- e(ii) The words '**WELD ONLY**' if the coupling body is specifically designed to be attached by welding only.

### Option 2 “Clause 12.4 of ADR 62 “Mechanical Connection Between Vehicles”

Markings complying with Clause 12.4 must be marked with the following:

- a) The manufacturer's name or trademark;
- b) Maximum allowable ATM rating in kilograms, e.g. 750kg, or 2000kg, or 3500kg; and
- c) The words “use with model (identified model)”.

## 7. Safety Chains - (VSB 1 Section 16)

- 7.1. Trailers with rigid drawbars (pig trailers) must be fitted with appropriately rated and identifiable safety chains in accordance with:

- a) **For trailers with an ATM up to 3500kg ([Table 1](#))**

Australian Standards AS 4177 – 1994 or AS 4177 – 2004 “*Caravan and light trailer towing components - Part 4 – Safety chains up to 3500kg capacity*”;

or

- b) **For trailers over 3500kg ATM ([Table 2](#))**

Australian Standards AS 2321-1979 or AS 2321-2006 “*Short link chain for lifting purposes*”.

**Note:**

- i. For trailers with an ATM up to 3500kg, safety cable may be used in lieu of safety chain providing the load capacity of the safety cable is not less than that of a chain complying with AS 4177 – 1994 or AS 4177 – 2004 for the ATM of the trailer.
- ii. Trailers up to 3500kg ATM – Work Load Limit applies.
- iii. Trailers over 3500kg ATM – Break Load Limit applies.

**7.2. Safety Chain Matrix (Guide Only)**

**Table 1 - For trailers up to 3500kg ATM**

<b>ATM (kg)</b>	<b>Minimum Chain Link Diameter (mm)</b>	<b>Work Load Limit (kg)</b>	<b>Number of Chains (minimum)</b>	<b>Marking</b> (1.5mm for chain < 8.0mm) (2.0mm for chain ≥ 8.0mm)	<b>Minimum Marking Frequency (link)</b>
0 to 1000	6.3	1000	1	4177-10	4th
Up to 1600	8.0	1600	1	4177-16	4th
Up to 2500	10.0	2500	1	4177-25	4th
Up to 3500	13.0	3500	2	4177-35	4th

**Table 2 - For trailers over 3500kg ATM**

<b>ATM (kg)</b>	<b>Minimum Chain Link Diameter (mm)</b>	<b>Break Load Limit (kg)</b>	<b>Number of Chains (minimum)</b>	<b>Marking</b>	<b>Minimum Marking Frequency (link)</b>
Up to 4500	6.0	4607	2	(Manufacturer's Mark), "T", "8", "80" or "800"	20th or 1m

**7.3. Safety Chain Markings - ATM not exceeding 3500kg**

- 7.3.1. The marking on complying chain is repeated at intervals not exceeding 4 links and the characters on the links are at least 1.5mm high (chains less than 8.0mm link diameter) and not less than 2 mm high (chains 8.0mm and above).

**7.4. Safety Chain Markings - ATM exceeding 3500kg**

- 7.4.1. Each length of chain shall be permanently and legibly marked at intervals of not more than 20 links or one metre with the marking being either raised or indented.

**7.5. Safety Chain Shackles**

- 7.5.1. Refer to [Vehicle Inspectors Bulletin 13\(i\) "Light Trailer Safety Chain Shackles"](#).

## 7.6. Drawbar Attachment

- 7.6.1. The safety chain must be attached to the trailer as near as practicable to the coupling to retain connection to the towing vehicle and prevent the drawbar from hitting the ground in the event of coupling failure.
- 7.6.2. Where welding is permitted to attach the safety chain to the drawbar, the weld must cover at least 50% of the length of the link and the adjoining link must be able to move freely within the welded link. **Grade "T" chain must not be welded.**
- 7.6.3. The drawbar safety chain attachment point should not come in contact with the ground at any time.

## 8. Axle Rating (including wheels and tyres) and Suspension - (VSB 1 Section 19)

- 8.1. Where two or more axles are fitted within an axle group, the axles must be related to each other through a load-sharing suspension.
- 8.2. This requirement does not apply to a close coupled axle group providing the load carrying capacity of each axle in the axle group, including the wheels and tyres fitted to each axle, is at least 120% of the ATM of the trailer.

A close coupled axle group is:

Axle Group	Number of Axles	Extreme Axle Spacing
Single Axle	2	≤ 2.0m
Tandem Axle	3	≤ 3.2m
Triaxle	4	≤ 4.0m

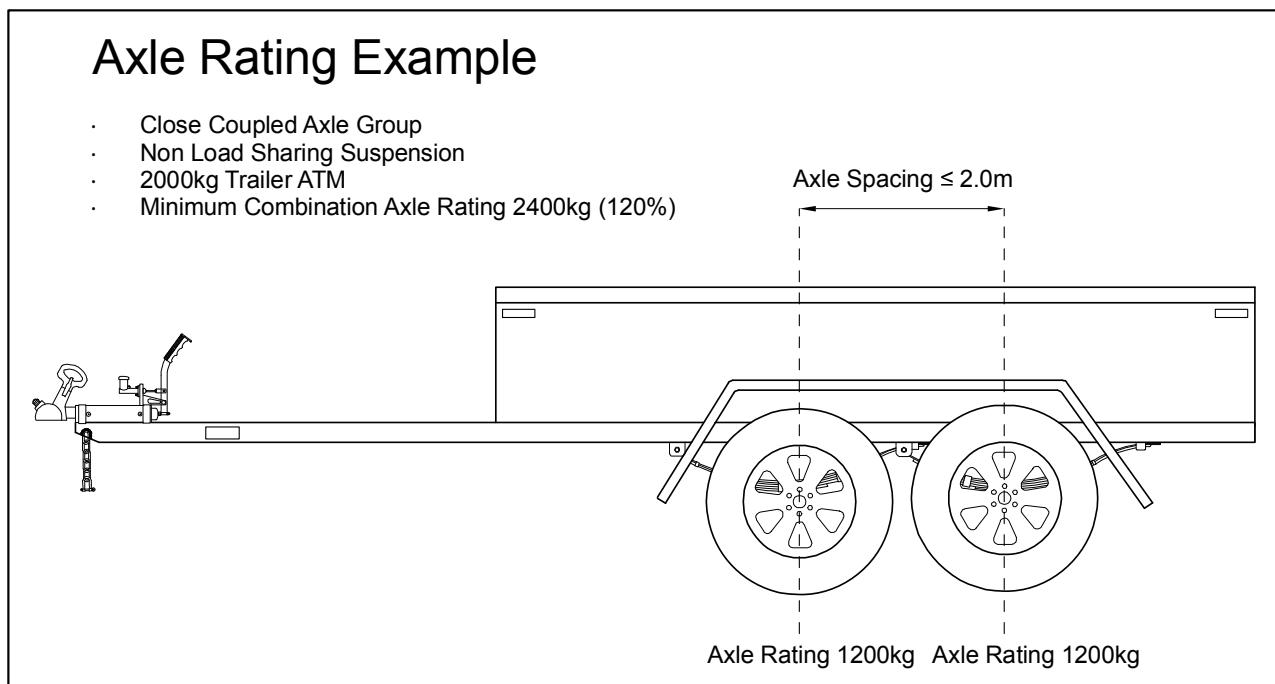

## 9. Maximum Trailer Dimensions (Pig Trailers) - (VSB 1 Section 21)

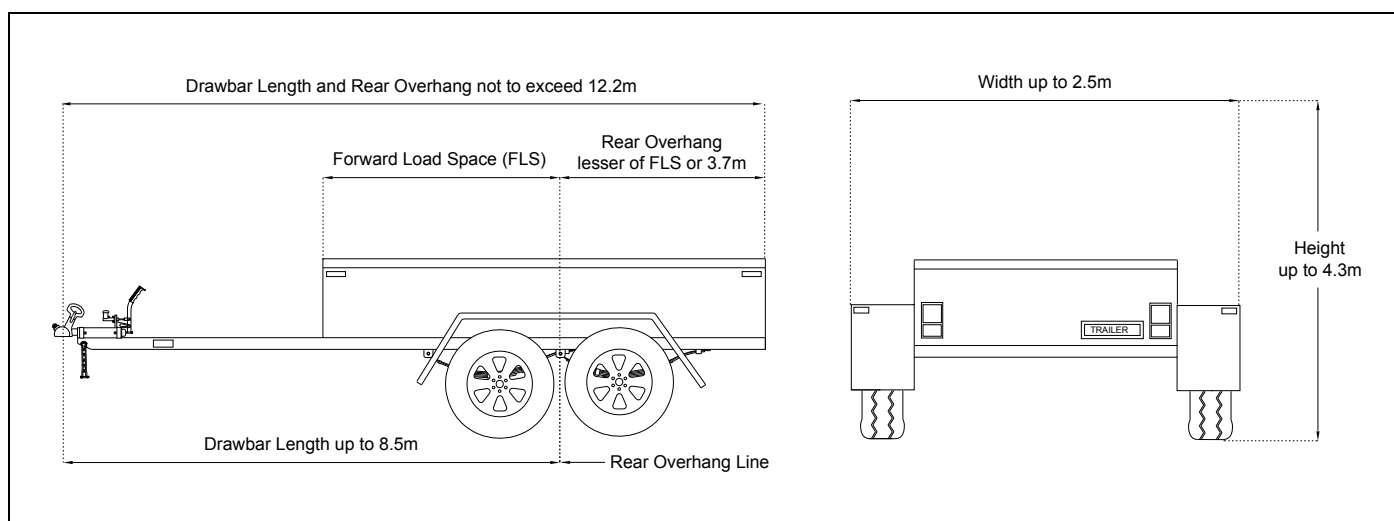

### Note:

- i. *Trailer width is measured across the body including wheel guards, but excluding signalling devices and side-mounted lamps.*
- ii. *Rear Overhang must not exceed Forward Load Space (FLS) or 3.7m – whichever is the lesser.*
- iii. *Drawbar length, Forward Load Space (FLS) and Rear Overhang must be measured from the rear overhang line.*
- iv. *Drawbar length is measured from the point of articulation on the tow coupling.*
- v. *Overall length, including load and equipment, not to exceed 12.5m*
- vi. *Trailers manufactured to exceed dimension limits (i.e. aeroplane glider trailers) will require approval from the Commonwealth Department of Infrastructure, Transport, Regional Development and Local Government – refer VSB 1.*

## 10. Weblinks and References

[ADR 62/00](#), [ADR 62/01](#) and [ADR 62/02](#) “Mechanical Connection Between Vehicles”

[Vehicle Standards Bulletin \(VSB\) 1 – Building Small Trailers](#)

[Information Bulletin V13 “Vehicle Dimensional Limits \(Including Load\)”](#)

[Information Bulletin V65 “Northern Territory Requirements for A-Frame Towing of Vehicles”](#)

[Vehicle Inspectors Bulletin 13 \(i\) - “Light Trailer Requirements – Compliance with VSB1”](#)